

**SECOND FLOOR**

SCALE: NOT TO SCALE

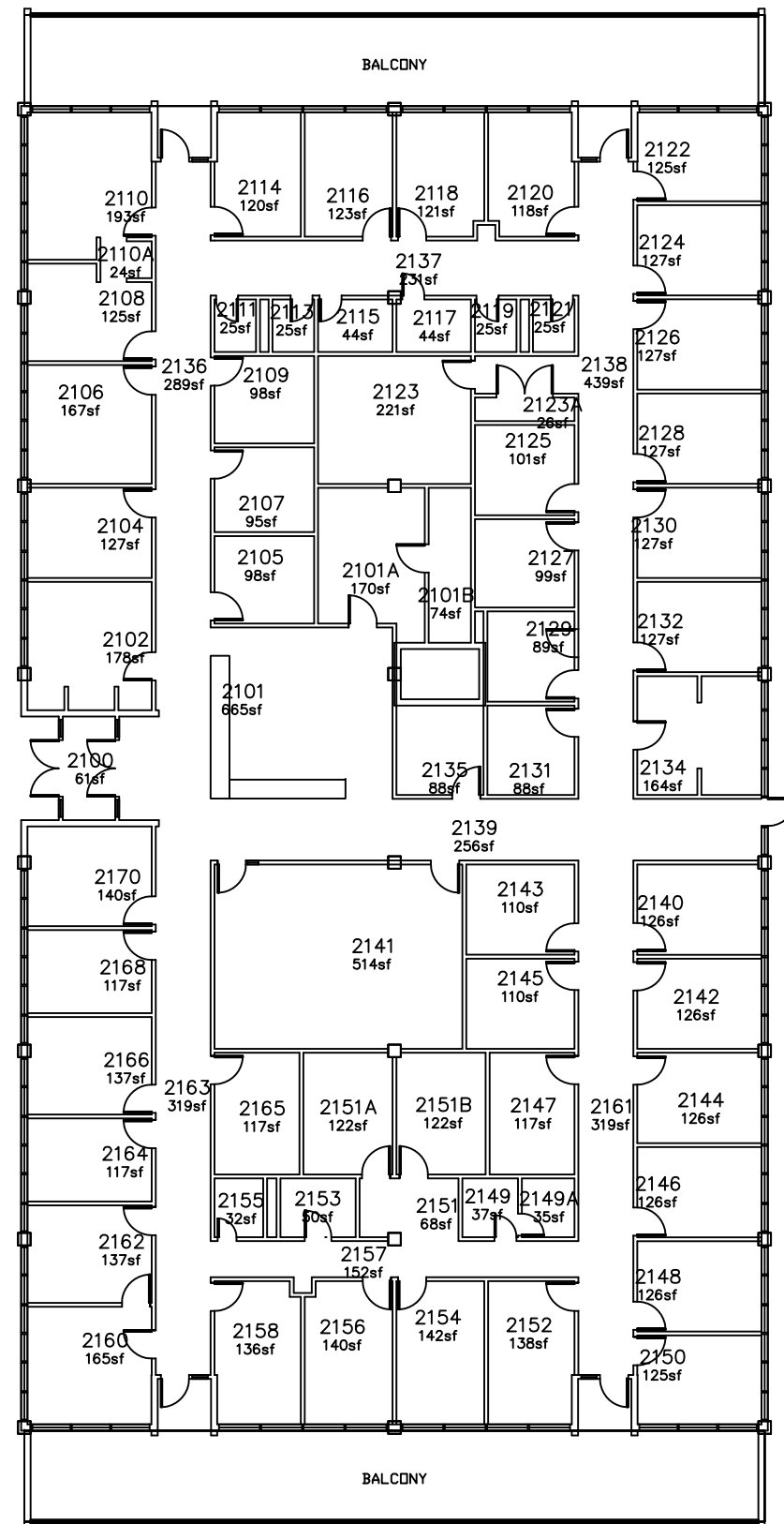

NORTH



**PLANNING & CAMPUS DEVELOPMENT**  
OFFICE OF SPACE MANAGEMENT

TOTAL FLOORS:	3	FLOOR:	SECOND
TOTAL GROSS SQUARE FEET:	45851	GROSS SQUARE FEET:	22006

▲ MAIN ENTRANCE      ▲ SECONDARY ENTRANCE

**R.O. ANDERSON SCHOOL OF MANAGEMENT**

**SECOND FLOOR**  
1924 LAS LOMAS RD NE

**#0076**

2 OF 3  
076-00-02